



Piston-Vibrators FP-50 to 95

Pneumatic piston vibrators for linear vibration with unlimited fine-tuning facilities for amplitude and frequency.

Properties

- Quiet and efficient
- Rated frequency 1'800 – 2'800 min⁻¹
- Force 490 – 6'150 N
- Continuously variable
- Applicable up to 120°C, HT version up to 150°C and LT version down to -40°C on request
- Resistant against extreme environmental conditions
- Also available with ATEX certification

Field of application

- Driving conveyor and discharge chutes
- Loosening or compacting of bulk solids
- Activating of mechanical processes
- Filling facilities

Construction

Aluminium housing surface-hardened and corrosion-resistant

Dimensions and weights

Model	A [mm]	B [mm]	C [mm]	D [mm]	E [mm]	F [mm]	G Thread	H Thread	J Thread	K	Weight [kg]
FP-50-M	154	∅ 84	90	72	20	8.8	G 1/4"	G 1/4"	G 1/4"	M16	3.30
FP-60-M	154	∅ 94	110	90	20	8.8	G 1/4"	G 3/8"	G 1/4"	M16	4.25
FP-95-M	157	∅ 140	150	125	20	13.0	G 3/8"	G 3/8"	G 3/8"	–	9.46

FP-50 and 60

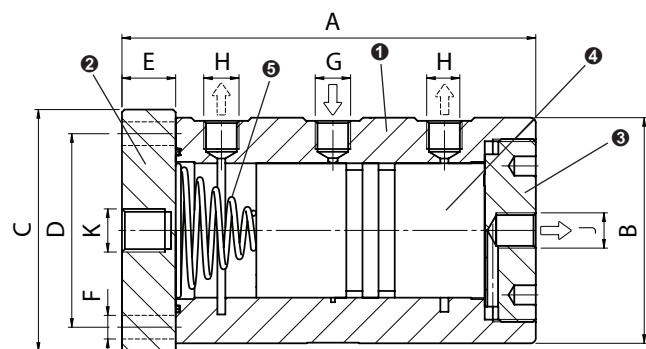

- ❶ Housing of hard anodized aluminium alloy
- ❷ Baseplate Ematal-coated
- ❸ Cap anodized
- ❹ Piston of leaded-bronze
- ❺ Compression spring

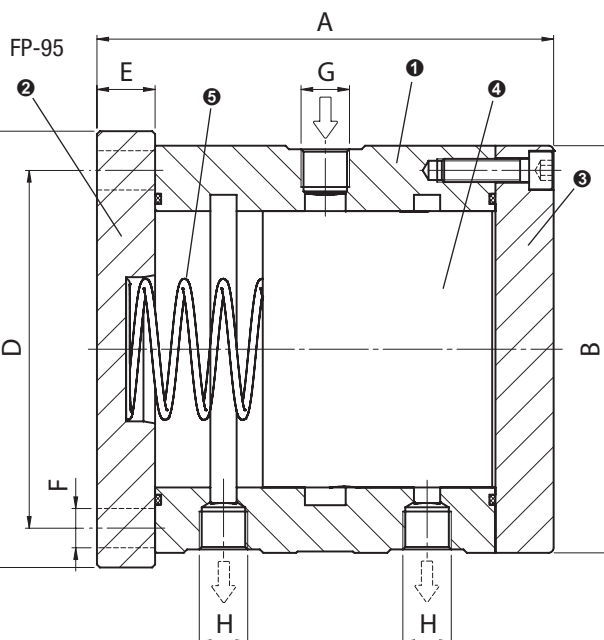

Technical data

Model	Vibrations [x 1000 min ⁻¹]			Force [N]			Air consumption [l/min]		
	2 bar	4 bar	6 bar	2 bar	4 bar	6 bar	2 bar	4 bar	6 bar
FP-50-M	1.8	2.3	2.8	490	970	1'660	48	100	190
FP-60-M	1.9	2.4	2.7	610	1'400	2'170	90	160	270
FP-95-M	1.8	2.4	2.8	1'620	4'060	6'150	170	320	450