

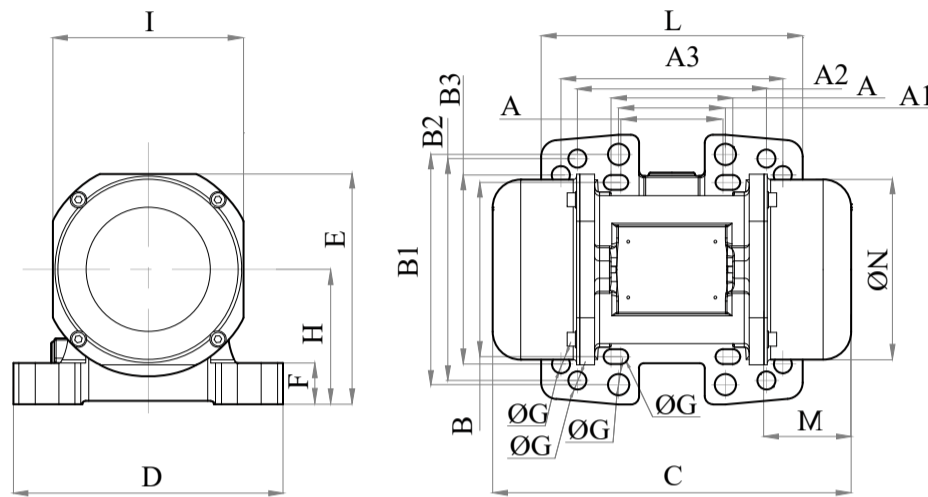

# MVE 200/3N-23A0-24V (ENZ0020023A02A0000)

DC - 2 poles - 3000 RPM - 24 V - DC

Working moment (Kg*cm)	Unbalance (Kg*cm)	Centrifugal force (Kg)	Nominal voltage (V)	Input power (kW)	Current (A)	Power factor	Ia/In
4,17	2,09	200	24	0,16	6,7		4



OVERALL DIMENSIONS (mm)																					
Weight (Kg)	A	A1	A2	A3	B	B1	B2	B3	G	G1	G2	Holes number	C	D	E	F	H	I	L	M	N
7,2	62-74	65	115	135	106	140	135	115	9	13	11	4	218	164	140	25	82	116	159	53	110

TECHNICAL FEATURES						
Type of grease	Greased for life	Screw	Washer	Clamping torque (Nm)	Cable type	Cable gland
/	Yes	M8-M10-M12	8,4 x 16 - 10,5 x 20 - 13 x 24 mm	23-80-45	2G1.5 90°	M16 80°C

BEARINGS				
Bearing model	Type	Life 100%	Life 80%	Life 50%
6301-6302 2Z		3732	6469	30139

CERTIFICATION	
Atex II 3D Ex tc IIIc Tx IP66 [Tx Size 10-30:100°C - Tx Size 40-91:135°C] T.Amb -20/+40°C	