

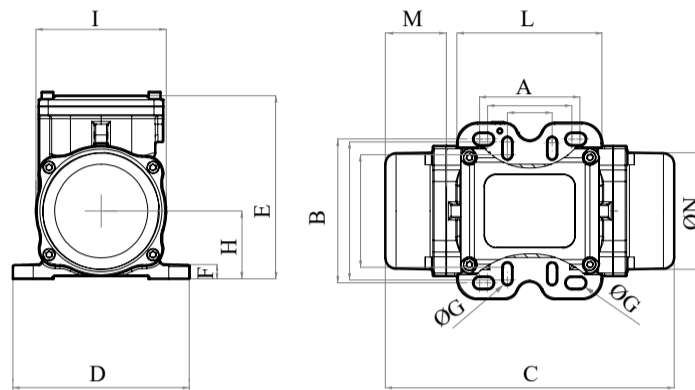

MVE 100/3E-10A0 (EE20010010A0JA0000)

3 PH - 2 poles - 3000 RPM - 220-240/380-415 V - 50 Hz

Working moment [Kg*cm]	Unbalance [Kg*cm]	Centrifugal force [Kg]	Nominal voltage [V]	Input power [kW]	Current [A]	Power factor	Ia/In
1,96	0,98	98	220-240/380-415	0,09	Δ 0,43 Y 0,25	0,68	3,2







*Technical drawings are illustrative purposes only, please refer to 2D/3D drawings available on "FINDER" app.
Contact us for more information.

OVERALL DIMENSIONS [mm]																
Weight [Kg]	A	A1	B	B1	G	G1	Holes number	C	D	E	F	H	I	L	M	N
5	62-74	33	106	83-102	9	7	4	213	130	135	10,5	50	96	107	45	85

TECHNICAL FEATURES						
Type of grease	Greased for life	Screw	Washer	Clamping torque [Nm]	Cable type	Cable gland
/	Yes	M8-M6	8,4 x 16-6,4 x 12 mm	23-9	4G1.5 80°C	M16 80°C

BEARINGS LIFE HOURS				
Bearing model	Type	100% C.F	80% C.F	50% C.F
6302 2Z		38366	74933	>100000

CERTIFICATION	
ATEX II2 D Ex tb IIIC Tx Db IP66 IECEx Ex tb IIIC Tx Db IP66 CLASS II DIV.2 GROUP F,G T4 Ex tb IIIC Tx Db IP66 [Tx Size Micro,10-30:100°C - Tx Size 40-91:135°C] CONFTO UL1004-3, UL1004-1,UL 60079-0,UL60079-31 CERT. CSA C22.2 No.100,CSA C22.2 No.77, CSA C22.2N.60079-0,CSA C22.2N. 60079-31 T.Amb -20/+40°C	    

REV.3-12/07/2019

Dimension with coarse degree of accuracy related to UNI 22768/1 Rights reserved to modify technical specifications.